



World leader in vehicle de-pollution technology



# SEDA Natural gas burner L-34004

Secure tank emptying  
for natural gas (CNG)



## Gas burner for flaring of natural gas Special design for draining CNG vehicle tanks

- Environmentally friendly disposing of CNG
- Easy to use

Do you need to exhaust gas systems of motor vehicles, it should be checked by aspiration or flaring on a particularly marked area.



### Accessories and equipment:

- Burner with burner pipe, 560 mm long
- Telescopic stand max. useful height up to 2,5 m
- Isolation ball valve
- Gas withdrawal fuse and flame arrestor
- Natural gas pressure regulator,  $p_e = 220 \text{ bar}$ ,  $p_a = 3-4 \text{ bar}$
- Natural gas hose,  $l = 10 \text{ m}$ , DN 20, PN 16 (Connecting line from the existing natural gas-pressure regulator to torch)
- Natural gas high pressure hose,  $l = 0,5 \text{ m}$ , PN 300, DN 8 as a connection from the gas tank to the pressure regulator
- Cartridge burner with piezo ignition
- Leak detection spray frost proof 400 ml
- Gloves

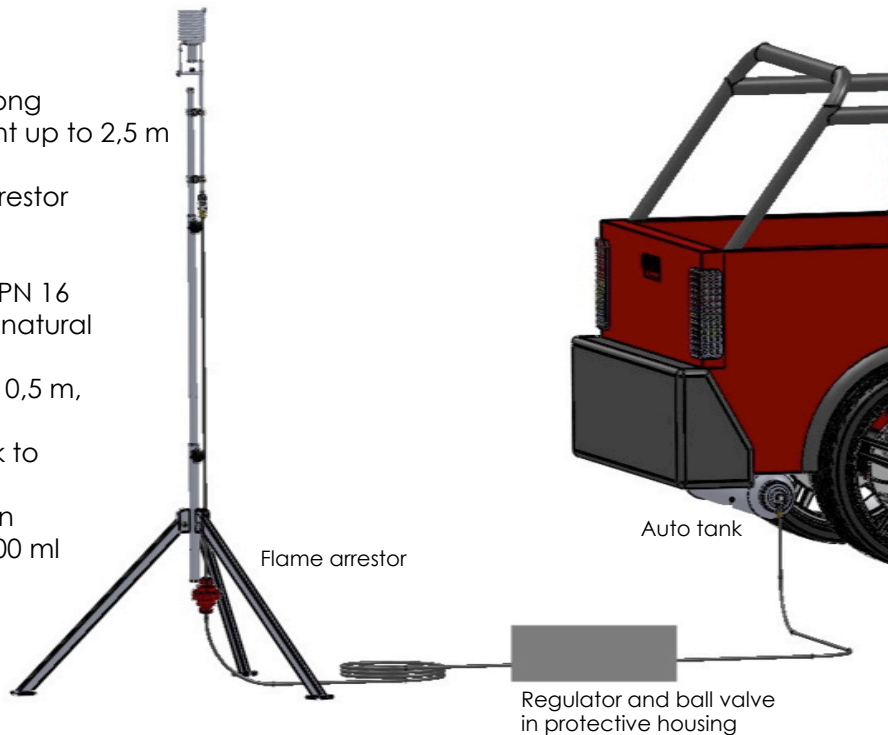

### TECHNICAL DETAILS

Useful hight: up to 2,5 m

### OPRDER INFORMATION

L-34004 SEDA gas burner



### SEDA-Umwelttechnik GmbH

Schwendter Str. 10 / A-6345 Kössen/Tirol/Austria  
UID-Nr.: ATU56621622 / FB-Nr.: FN 231790 v / FB-Gericht: Innsbruck  
Zertifizierter Betrieb nach DIN EN ISO 9001

T: +43 5375 6318-0  
F: +43 5375 6318-9  
E: info@seda.at  
Web: www.seda.at